

**ELEVATION 1-1**  
INCINERATOR HOUSE Scale 1: 100

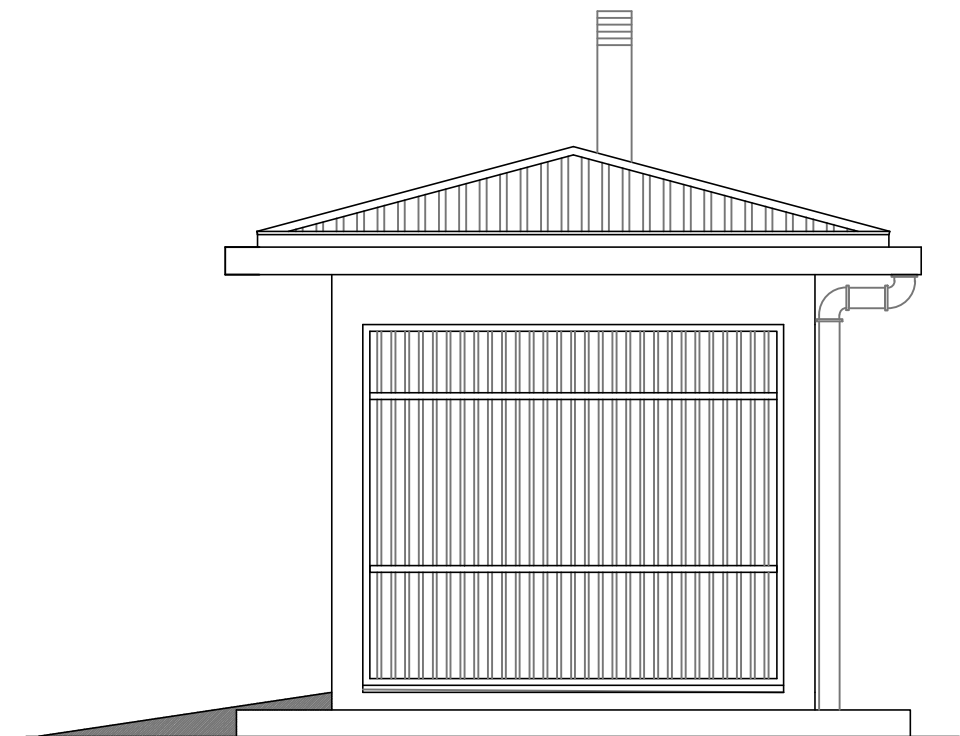

**ELEVATION 2-2**  
INCINERATOR HOUSE Scale 1: 100

CONSULTANT :

M/S ISDEFE  
Beatriz de Bobadilla, 3  
28040 MADRID

CLIENT : **GOVERNMENT OF UGANDA**  
MINISTRY OF HEALTH  
PLOT 6/7 LOUDRDEL ROAD  
P.O.BOX 7272  
FAX 0414231584

REFURBISHMENT AND EQUIPPING OF  
BUSOLWE GENERAL HOSPITAL  
LOCATION: BUTALEJA, UGANDA  
BUILDING NAME:

NOTES:  
All dimensions are given in millimeters

Scale:		Project No:
Date :		Version :
Drawing name:	INCINERATOR BUILDING ELEVATIONS.	SHT NO :

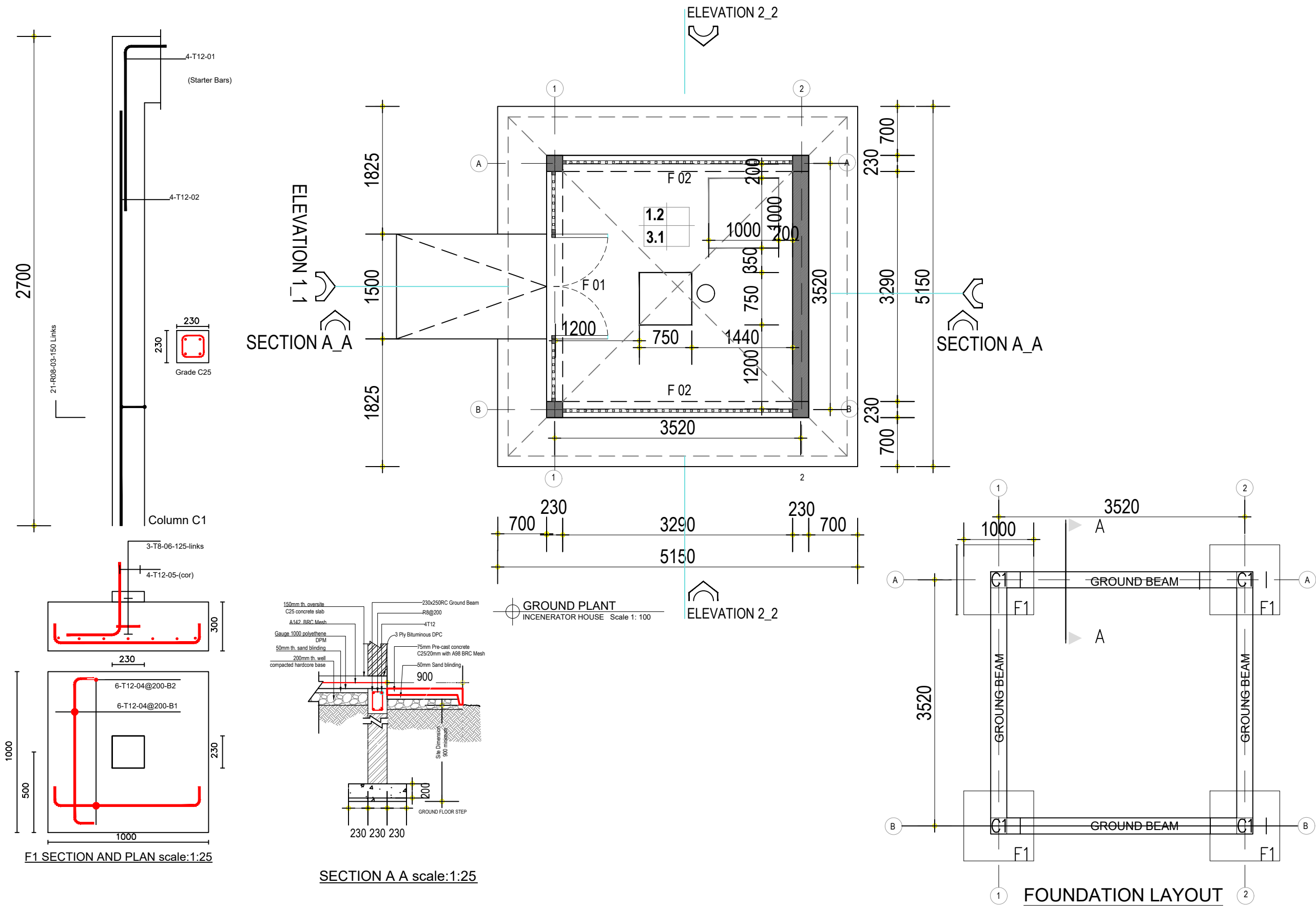

CONSULTANT :  
 M/S ISDEFE  
 Beatriz de Bobadilla, 3  
 28040 MADRID

CLIENT : **GOVERNMENT OF UGANDA**  
 MINISTRY OF HEALTH  
 PLOT 6/7 LOUDRDEL ROAD  
 P.O.BOX 7272  
 FAX 0414231584

REFURBISHMENT AND EQUIPPING OF  
 BUSOLWE GENERAL HOSPITAL  
 LOCATION: BUTALEJA, UGANDA  
 BUILDING NAME:

NOTES:  
 All dimensions are given in millimeters

Scale:		Project No:
Date :		Version :
Drawing name:	INCINERATOR BUILDING FOUNDATION DETAILS	SHT NO :

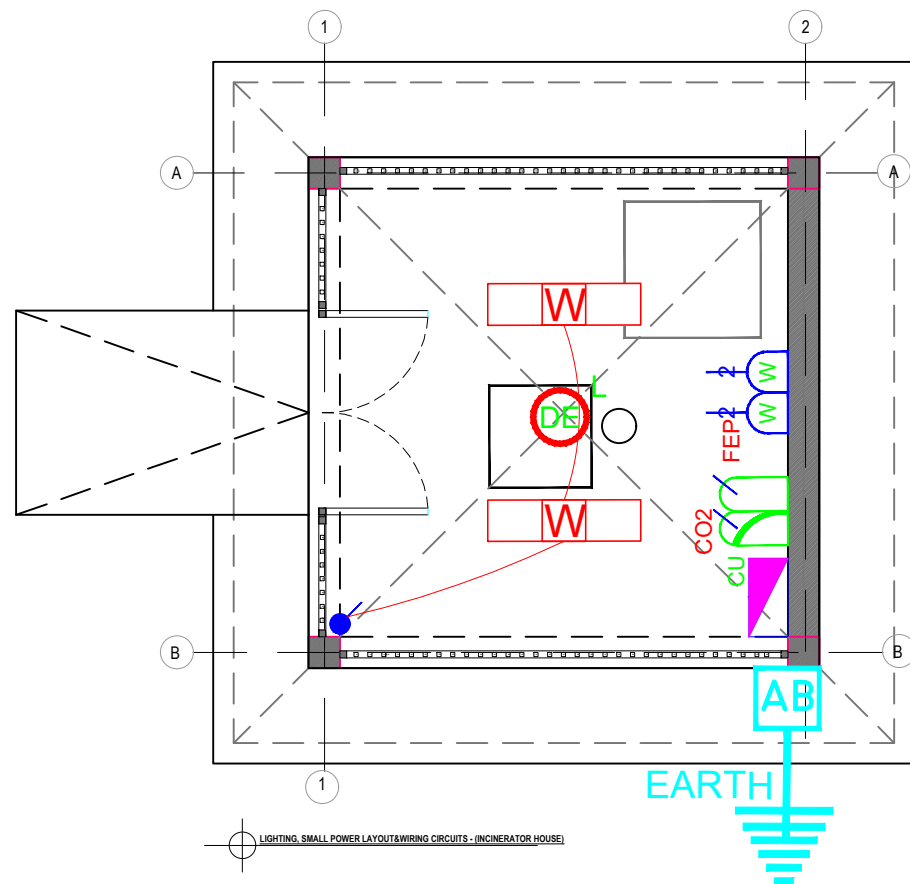

SYMBOL	DESCRIPTION
	Waterproof LED luminaire, 1500 mm, IP65, IK08, 57W
	6A 1 gang 1 way light switch
	13A two Gang switched Socket outlet on wall.
	Distribution Board
	6kg Carbondioxide type, wall mounted fire extinguisher
	9kg Monoammonium phosphate Grade IAIB dry powder type, cartridge operated, wall mounted fire extinguisher
	Emergency Surface Bulkhead for 1x18W CFL Lamp with 3 Hour Battery

FROM MDB

Wired BY 3c X 16mm<sup>2</sup> PVC/PVC  
Copper Cables.

32A  
SPN

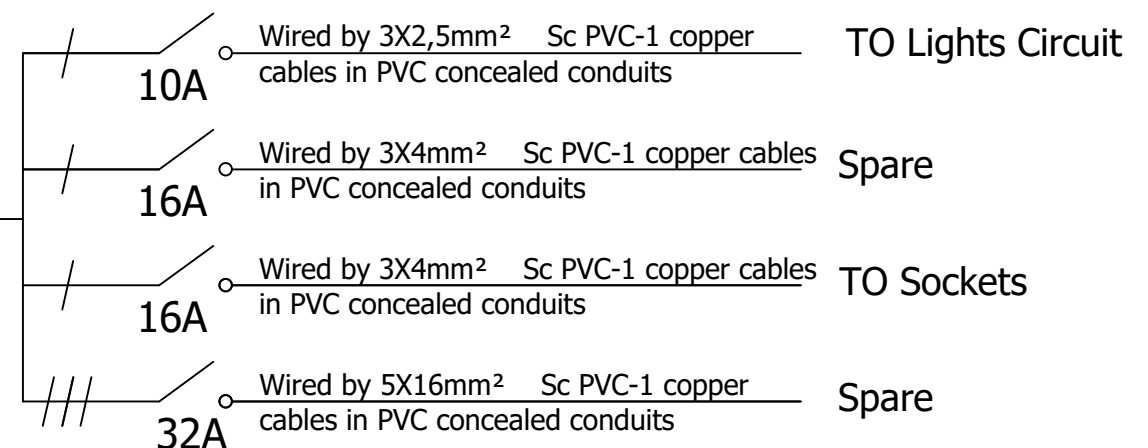

### 32A,SPN 4-WAY CONSUMER UNIT FOR FLUSH MOUNTING (CU)

CONSULTANT :	M/S ISDEFE Beatriz de Bobadilla, 3 28040 MADRID	CLIENT : GOVERNMENT OF UGANDA MINISTRY OF HEALTH PLOT 6/7 LOUDRDEL ROAD P.O.BOX 7272 FAX 0414231584	REFURBISHMENT AND EQUIPPING OF BUSOLWE GENERAL HOSPITAL LOCATION: BUTALEJA, UGANDA BUILDING NAME:	NOTES: All dimensions are given in millimeters	Scale:	
					Date :	
					Drawing name:	INCINERATOR BUILDING M&E

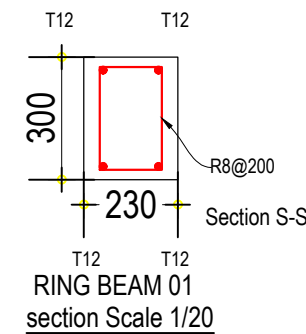
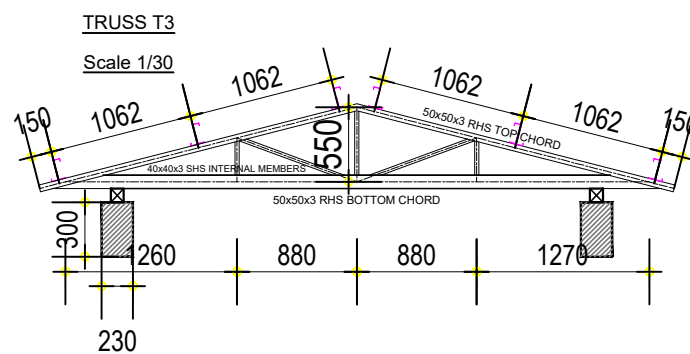
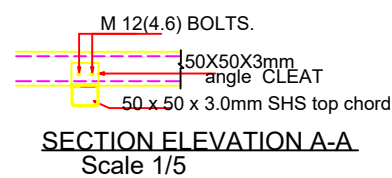
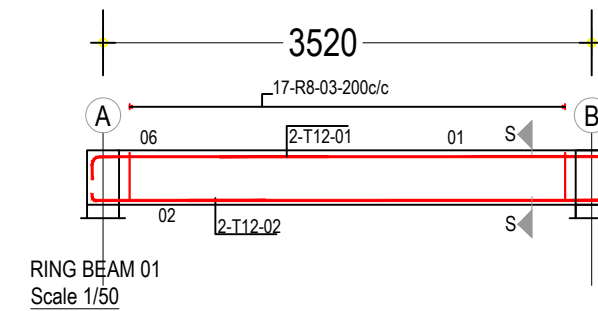
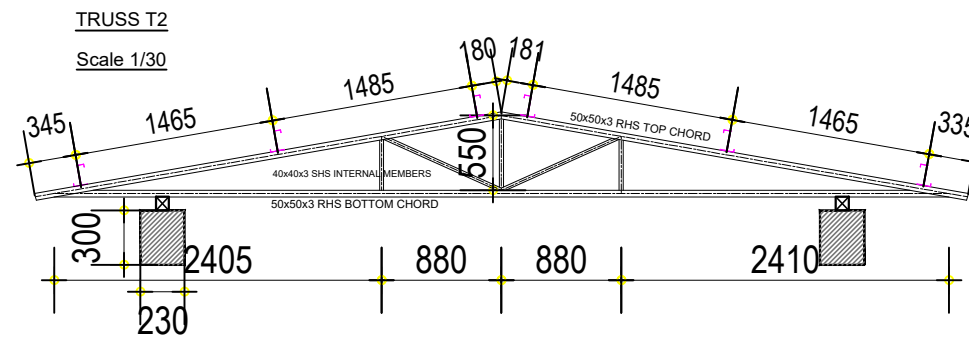
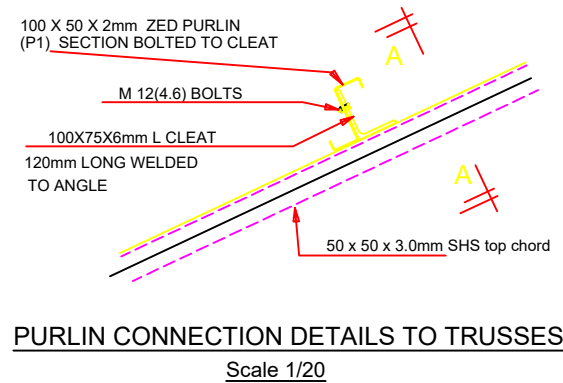
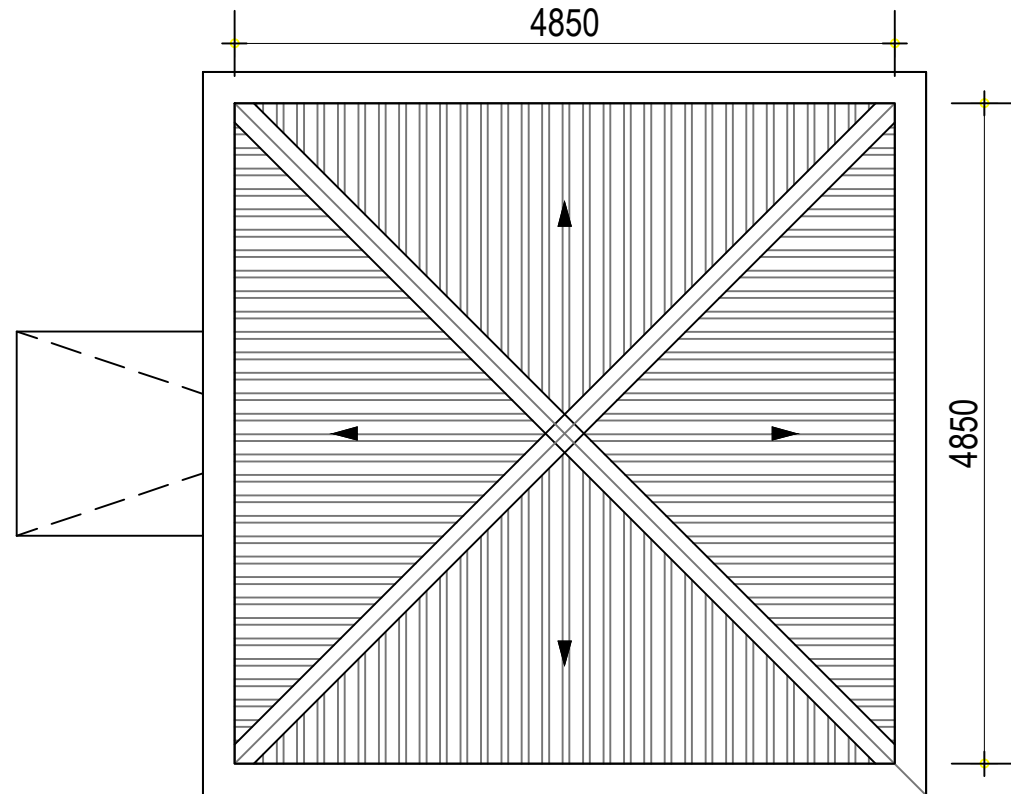
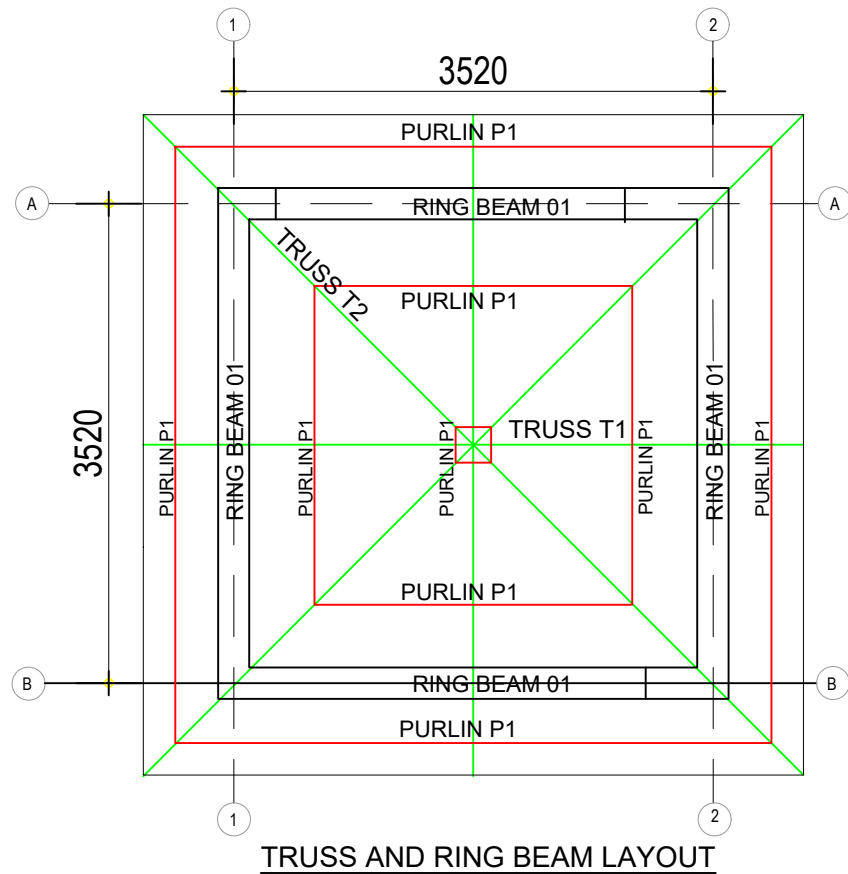

CONSULTANT :

M/S ISDEFE  
Beatriz de Bobadilla, 3  
28040 MADRID

CLIENT : **GOVERNMENT OF UGANDA**  
MINISTRY OF HEALTH  
PLOT 6/7 LOUDRDEL ROAD  
P.O.BOX 7272  
FAX 0414231584

REFURBISHMENT AND EQUIPPING OF  
BUSOLWE GENERAL HOSPITAL  
LOCATION: BUTALEJA, UGANDA  
BUILDING NAME:

NOTES:  
All dimensions are given in millimeters

Scale:		Project No:
Date :		Version :
Drawing name:	INCINERATOR BUILDING RING BEAM AND ROOF DETAILS	SHT NO :