

PLAN VIEW
SCALE: 1:18

250 LITRE CAPACITY ENERGY SAVING WOOD STOVE

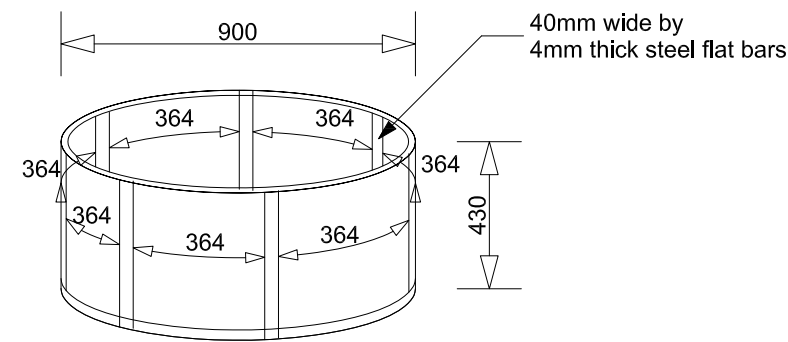
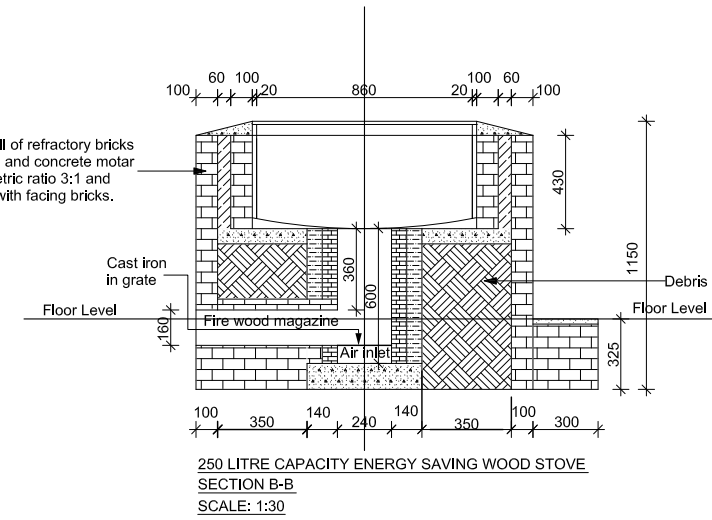
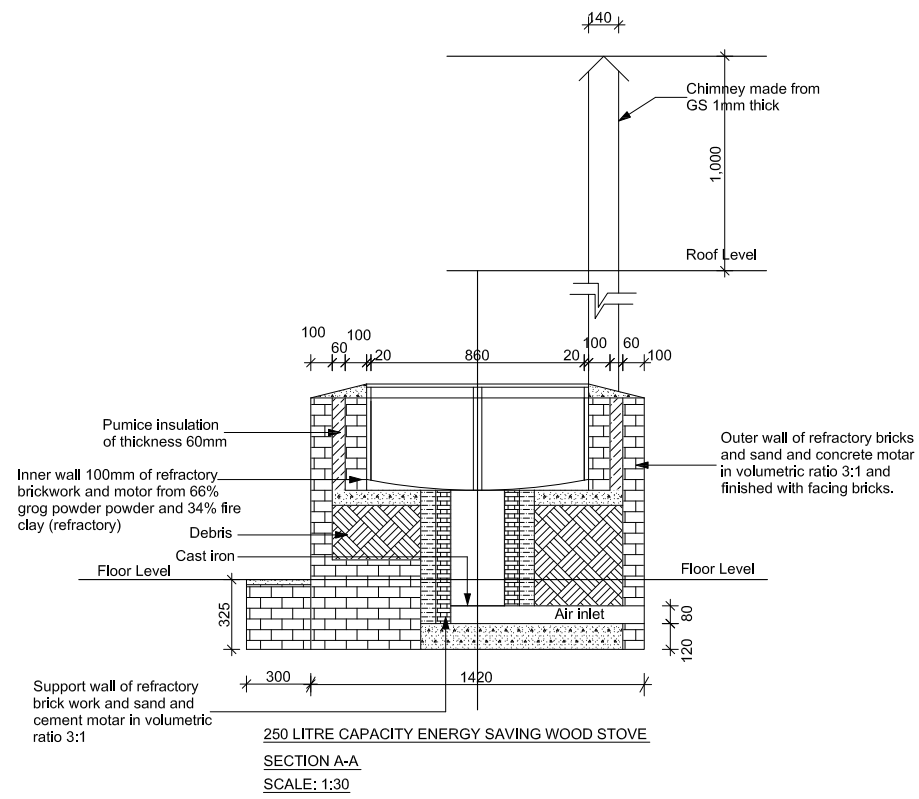

Cylindrical steel pot stabilizer for 250 litre capacity cooking pot made from 40mm wide by 4mm thick flat steel bars

SCALE: 1:18

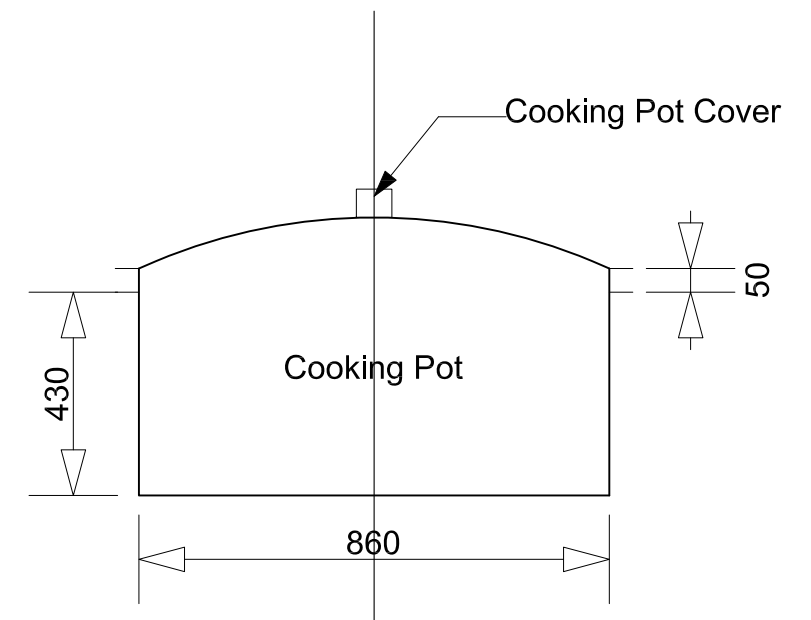

SCALE: 1:14